



mixertrucks.com
CHAPARRAL
CONCRETE EQUIPMENT

MAIN OFFICE
1701 W. Northwest Hwy
Grapevine TX, 76051

Tel: 817-329-9935
Fax: 817-329-9936
1-888-886-4937



1985 Rustler 110 5yd (110 YD³/HR)

AGG BIN 40T IN 4 COMPARTMENTS

AGG BATCHER 5 YARD CPMB RATED

IN TRUSS CEMENT SILO 225 BBL CPMB
RATED,

CEMENT FEEDERS 2 - 6" SCREW
CONVEYOR, 10HP

CEMENT BATCHER AIR VIBRATOR
AERATION PADS, 10"
BUTTERFLY

BATCH TRANSFER BELT 28' WIDE, 380
FPM, 4" 35⁰, CEMA B IDLERS
TWO PLY BELT 15 HP,
BACKSTOP

WATER SYSTEM 2" WATER METER
ELECTRICAL SYSTEM

440 V POWER PANEL WITH
STARTERS FOR BATCH BELT

**MANUAL CONTROLS
& ANALOG SCALES**

File: 1985RUSTLER5_JK_TX



mixertrucks.com
CHAPARRAL
CONCRETE EQUIPMENT

MAIN OFFICE
1701 W. Northwest Hwy
Grapevine TX, 76051

Tel: 817-329-9935
Fax: 817-329-9936
1-888-886-4937

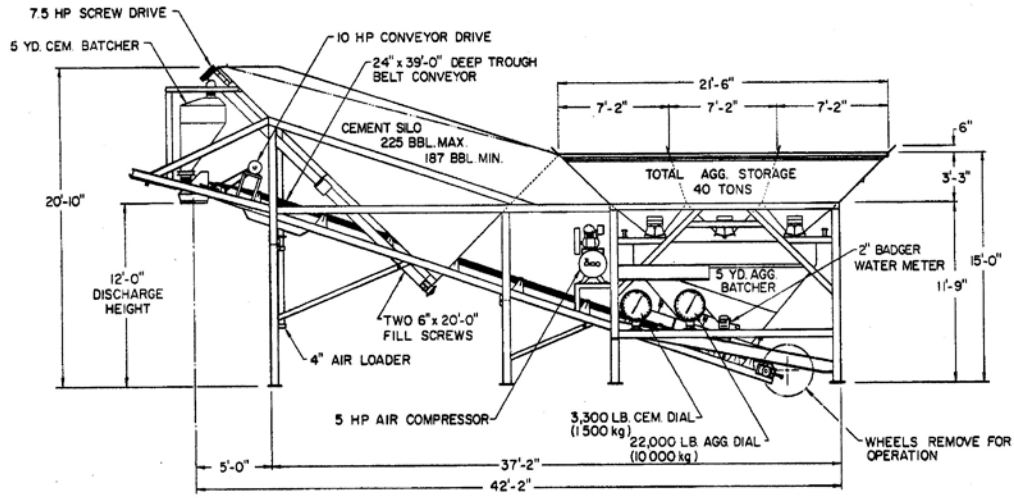

**ROSS MODEL 110 RUSTLER BATCH PLANT
5 YARD BATCHING SYSTEM**